

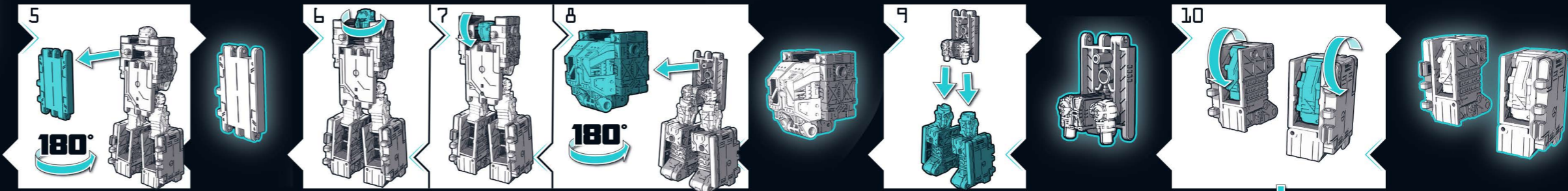

TRANSFORMERS EARTHRAISE WAR OF CYBERTRON TRILOGY

取扱説明書

対象年齢
15才以上

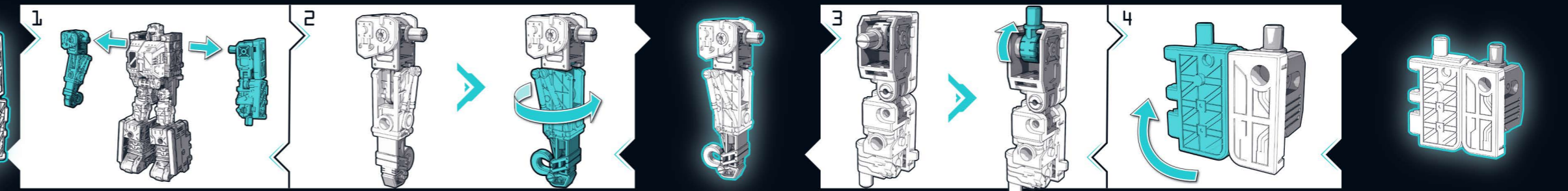
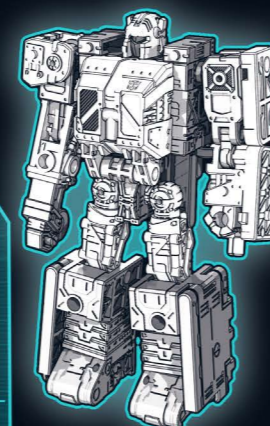

TRANSFORMERS

WFC-E8



IRONWORKS

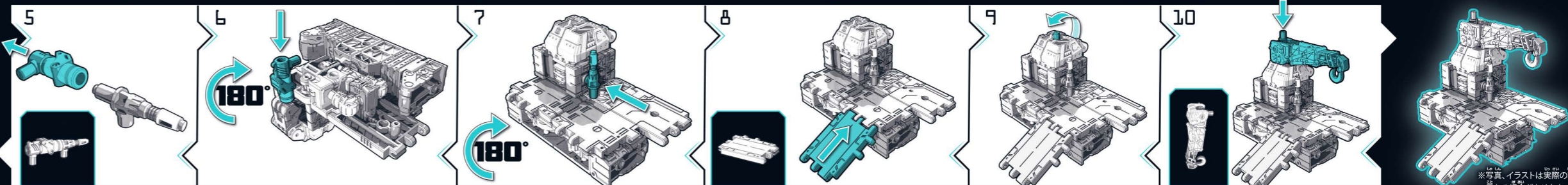
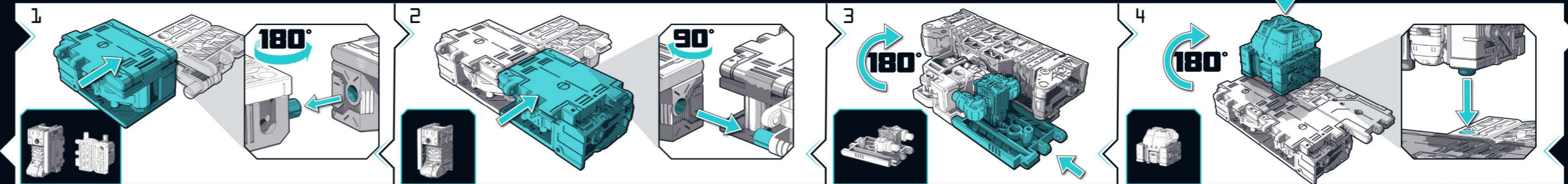
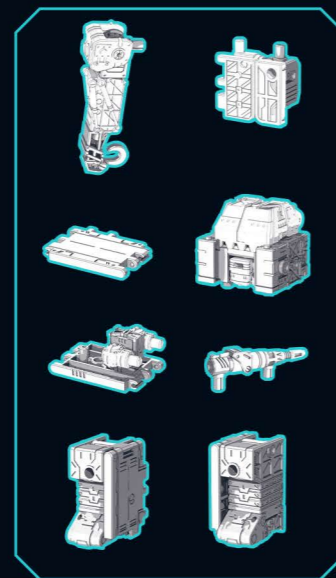

Manufactured under license from TOMY Company, Ltd. TRANSFORMERS and HASBRO and all related trademarks and logos are trademarks of Hasbro, Inc. © 2019 Hasbro, Pawtucket, RI 02861-1059 USA. HASBRO CANADA, LONGUEUIL, QC, CANADA J4G 1G2. US/CANADA TEL. 1-800-255-5516. Centro de Servicio para México: TEL. 5876-2998 y para el interior de la República TEL. 01-800-7-12-62-25. centroserviciomexico@hasbro.com. Manufactured by/Produced by: Hasbro SA, Rue Emile-Boëchat 31, 2800 Delémont CH. Represented by/Reprezentat de: Hasbro, De Entree 240, 1101 EE Amsterdam, NL. © Üretici Firma Bilgileri: Hasbro SA, Rue Emile-Boëchat 31, 2800 Delémont Isvicre TEL +41 324210800. Hasbro Oyuncak San. ve Tic. A.Ş., tarafından ithal edilmiştir. Tüketici Hizmetleri: Burhaniye Mah. Abdullahaga Cad. No: 51/2 34676 Beylerbeyi Istanbul Türkiye TEL +90 2164229010.



※写真、イラストは実際の商品と異なる場合があります。

※写真、イラストは実際の商品と異なる場合があります。

E7157/E7120 Asst. PN00044922

TRANSFORMERS EARTHRAISE WAR FOR CYBERTRON TRILOGY

(R) Retain instructions for future reference. (T) Conservez ces instructions pour référence ultérieure. (D) Bitte die Anleitung für spätere Rückfragen aufbewahren. (E) Conserve este instructivo para futuras referencias. (G) Guardar instrucciones para eventuales consultas. (I) Conserva le istruzioni come futuro riferimento. (N) Bewaar de gebruiksaanwijzing om later nog eens te lezen. (S) Spara instruktionerna för att kunna hänvisa till dem i framtiden. (V) Gem vejledninger til fremtidig referencebrug. (Ta vare på disse instruktionerne for fremtidig reference. (F) Säilytä nämä tiedot tulevaa tarvetta varten. (O) Φυλάξτε τις οδηγίες για μέλλοντική αναφορά. (Z) Zachowaj instrukcje na przyszłość. (U) Orižid meg a használati útmutatót. (I) Ileride bagrutamak izere talimatlan saklayın. (T) Tyto informace uschovejte pro budoucí použití. (P) Návod si odložte na použítie v budúcnosti. (P) Pastrează instrucțiunile pentru a le consulta în viitor. (C) Сохраните инструкции для будущего использования. (Z) Запазете инструкциите за бъдещи справки. (S) Sačuvajte upute za buduću upotrebu. (I) Instrukcija pasilikite ateičiai. (N) Navodila shraní, mogoče jih boš še potreboval. (Z) Збережіть інструкції для подальшого використання. (J) Jāta jūhised edasiseks kasutamiseks alles. (S) Saglabajiet instrukciju atsaucēi.

احفظ بالتعليمات للرجوع إليها في المستقبل.

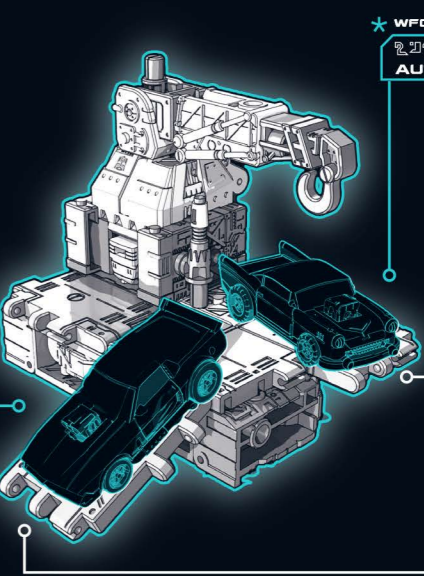
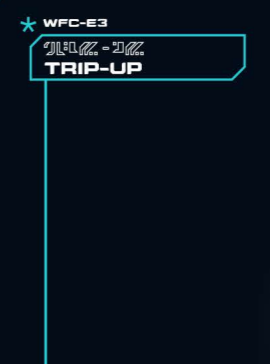
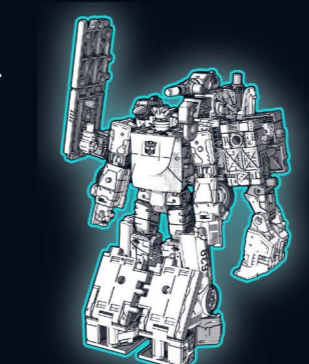
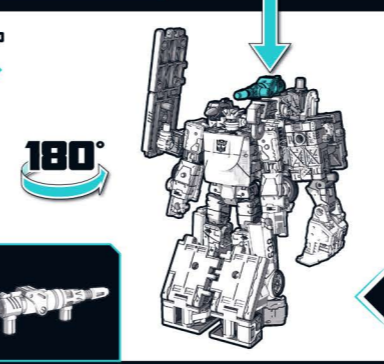
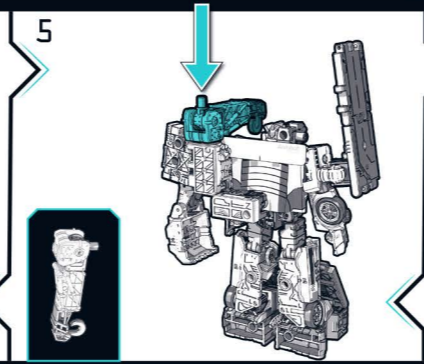
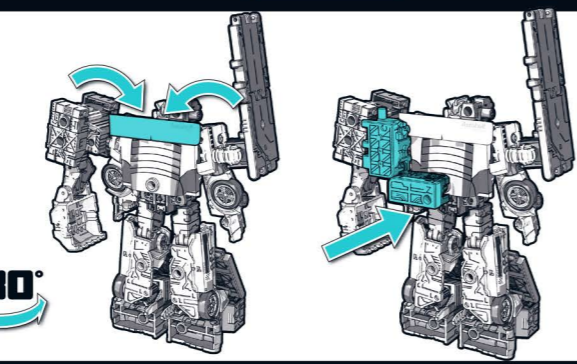
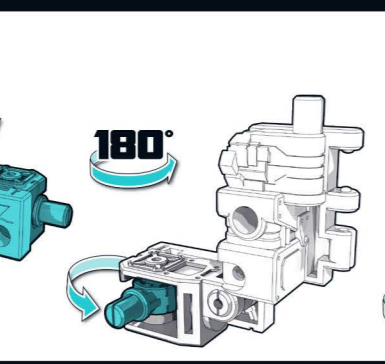
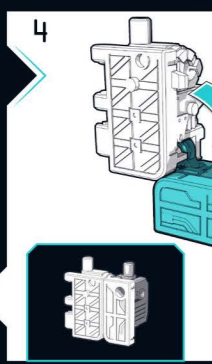
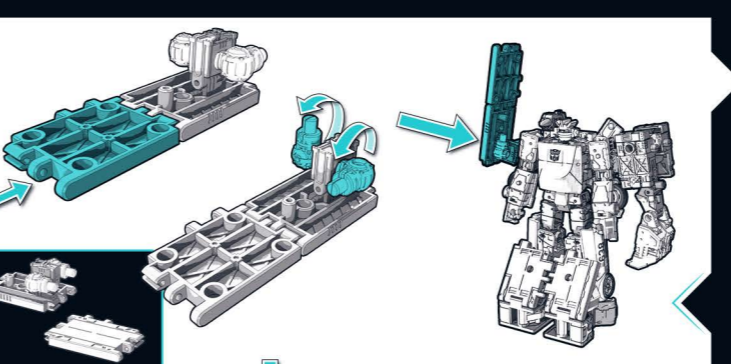
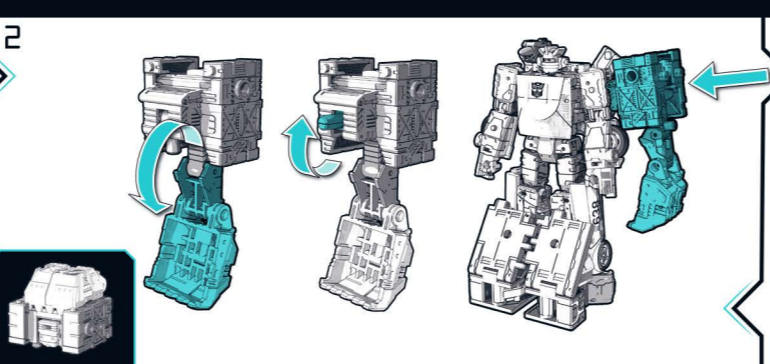
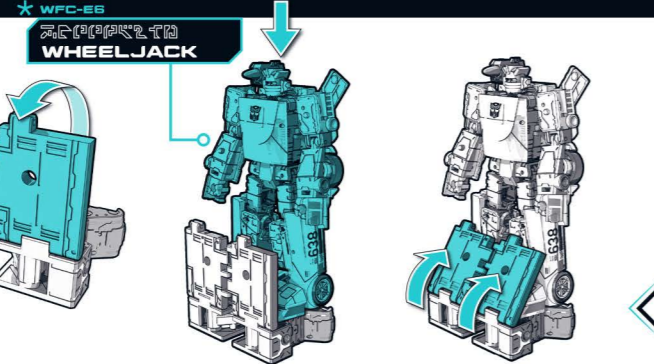
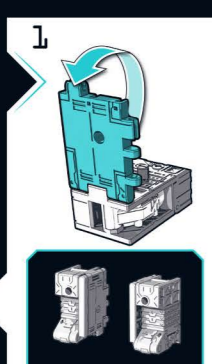
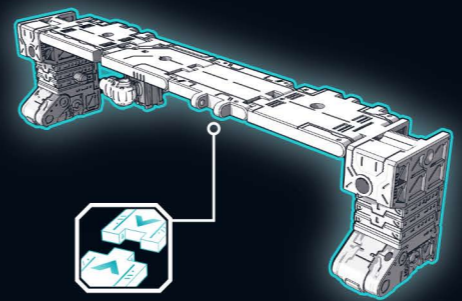
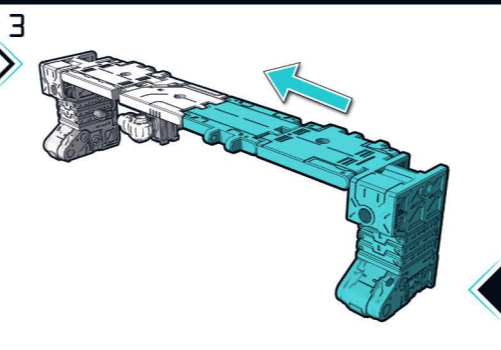
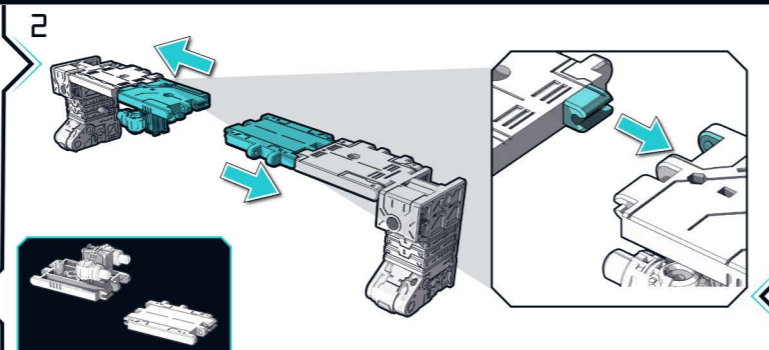
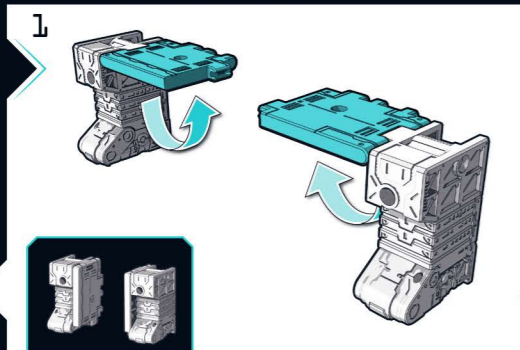

* (S) Sold separately. Subject to availability. (T) Vendus séparément. Dans la limite des stocks disponibles. (D) Separat erhältlich. Je nach Verfügbarkeit. (E) Se vende por separado. Sujeto a disponibilidad. (G) Vendidas em separado. Sujetas a disponibilidade. (I) Venduto separatamente, secondo disponibilità. (N) Afzonderlijk verkrijgbaar. Naargelang de beschikbaarheid. (V) Sālsjs separat. I māt av tilgāng. (S) Selges separat. Kan være udsolgt. (F) Selges separat. Med forbehold om tilgjengelighet. (O) Myydään erikseen. Saatavuu voi vaihdella. (O) Πωλείται ξεχωριστά. Εξαρτάται από τη διαθεσιμότητα. (Z) Sprzedawane oddzielnie. W zależności od dostępności. (U) Külön lehet megvásárolni. A készlet függvényében. (T) Ауди сатири. Стокларла синиридири. Продава се самостатне. В зависности од доступности. (C) Predáva sa zvlášť. Zavisí od dostupnosti. (P) Se vinde separat. În limita disponibilității. (P) Продається окремо. Уточняйте наличие. (S) Prodaja se zasebno. Ovisno o raspoloživosti. (I) Parduodama atskirai. Gali būti parduodama ne visur. (N) Naprodaj ločeno. Ovisno od raspoloživosti. (Z) Продається окремо. Наявність не гарантована. (J) Müükse eraldi. Kättesaadavus sõltub laoseisust. (S) Pārdod atsevišķi. Atkarībā no pieejamības.

※写真、イラストは実際の商品と異なる場合があります。
 *تباع بشكل منفصل. رهن التوفر.